

## TECHNIQUES *by G. Cloud*

# UNIFYING CONCEPTS IN TEACHING OPTICAL METHODS

The last four decades have produced many important advances in the discovery, understanding, and utilization of optical phenomena for measurement purposes, particularly in the broad field known as experimental mechanics. Teaching of the basic phenomena and their applications to engineering students is important and necessary, and this knowledge base continues to expand. But, the knowledge in other areas of engineering has also grown, and serious conflicts arise as to what should and can be taught within the limited scope of typical undergraduate and graduate engineering curricula. A complicating factor is that effective teaching of experimental mechanics demands investment of instructional time and hardware in laboratories.

One answer to the conflicting dynamics is to make the teaching of experimental mechanics, and optical methods in particular, more efficient. This can be accomplished in two ways, namely, (a) appropriate meshing of theory, study of techniques, and laboratory exercises; and (b) maximum exploitation of "transfer of learning" by recognizing and emphasizing fundamental concepts that unify the various methods.

## BACKGROUND

The approaches outlined here are drawn from experience in developing and teaching several courses involving experimental mechanics at Michigan State University and elsewhere. The first is a laboratory sequence that supports the required undergraduate course in mechanics of deformable solids. This lab incorporates experiments that require extensive computer-based strain gage data acquisition as well as demonstrations of photoelasticity and other techniques. The second is an elective senior-level course that covers most of the important methods of experimental mechanics, including strain gages, motion measurement, and optical methods. This course incorporates some required experiments and several demonstrations. The third is a core graduate course in strain and motion measurement that concentrates on strain gages, motion measurement with emphasis on seismic systems, and photoelasticity; with less-deep coverage of moire, holography, and speckle methods. The fourth course gives graduate-level in-depth instruction on optical measurement techniques. Both of the graduate courses require

*G. Cloud (SEM Fellow) is a Professor in the Materials Science and Mechanics Department at Michigan State University.*

*This paper was presented at the SEM 2001 Annual Conference on Experimental and Applied Mechanics.*

*Editor's Note: ET is launching a new Back to Basics Series for 2002 with a focus on Optical Methods. The Series begins by introducing the nature and description of light and evolves, each month, into topics ranging from diffraction through to phase shifting in interferometries. The intent is to keep the Series educationally focused by coupling text with illustrative photos and diagrams that can be used by practitioners in the classroom as well as in industry. The Series author is Professor Gary Cloud from Michigan State University who is internationally known for his work in optical measurement methods and for his recently published book titled, Optical Methods of Engineering Analysis. Series Editor: Kristin B. Zimmerman, Ph.D., kristin.b.zimmerman@gm.com.*

extensive laboratory involvement. Outlines of these courses are available on the web at [www.egr.msu.edu/~cloud](http://www.egr.msu.edu/~cloud).

Further, the author has offered short courses on optical methods of measurement to groups of various interests and backgrounds. These short courses have varied from 8 to 16 hours of instruction, and design of the sequences has required considerable thought about the most efficient ways of delivering the material. Typically, they do not involve laboratory participation, but portable demonstrations are used extensively to illustrate the concepts and techniques.

In all these courses, a certain number of case studies are incorporated to emphasize the importance of being familiar with a battery of techniques, the necessity for choosing appropriate techniques, the breadth of problems that can be solved through experimental methods, and the requirements for obtaining valid data. The idea that methods must be chosen and adapted to fit the measurement problem at hand, as opposed to the common approach of fitting the problem to a method that might be favored by the investigator, is emphasized.

These approaches have also been employed in teaching the fundamentals of optical methods, with case examples, to high school students in only one to three hours.

## ORGANIZATION OF THE MATERIAL

Conventional pedagogy typically involves systematic treatment of optics and interferometric theory, which might require several weeks of class time. Then, study of specific methods begins, after which laboratory experience occurs. The problem is that a term or semester might be half over before meaningful laboratory work can be performed.

A better approach is to integrate theory as much as possible with treatment of the optical techniques. This plan is utilized, although not to the maximum effective extent, in the book by the author<sup>1</sup> that is used in various ways in the courses mentioned above. Presented at the beginning are just enough of the optics concepts and theory to understand light sources, lenses, and basic interferometry. The concepts are then utilized in learning about some classic two-beam interferometry methods including Young's experiment, Newton's rings, and Michelson interferometry. Then, detailed study of the classic common path interferometry known as photoelasticity may be undertaken. The student can begin informed laboratory work as soon as about two weeks into the course. While the laboratory exercises on basic interferometry and photoelasticity are being completed, the next increment of theory can be presented, followed by study of a more advanced technique. This cycle is continued through the course. In all cases, the lectures and laboratory work are augmented by introduction of application examples that underline the utility of the techniques in solving practical problems.

## UNIFYING CONCEPTS IN OPTICAL METHODS

### UNIFYING CONCEPTS

The purpose here is not to discuss in detail an outline of what might be considered an effective course on optical phenomena and measurement techniques. Rather, emphasis is on concepts and processes that are common to the various techniques of optical methods of measurement. If these concepts are understood thoroughly, as they are needed, much time and effort is saved. Available space limits discussion to only some of the concepts and techniques, but these are sufficient to establish the paradigm, which is repeated and extended as the training develops.

As a general principle, emphasis is given to the fundamental physical phenomena that are utilized in each technique. With unifying concepts and physical foundations in hand, the student is poised to advance his breadth of knowledge beyond the limits imposed by course and curriculum boundaries.

### CONCEPTS INVOLVING LIGHT

At the beginning, it is usually necessary to teach the nature of light energy, insofar as it is known; the history and basic ideas of Maxwell's equations; the wave equation for non-conducting media; its simplest solution in the form of a harmonic wave, here considered only in trigonometric notation; the electromagnetic spectrum; polarization; radiation sources; intensity measurement as by square-law detectors including halide films and electronic devices; and, finally, basic lens functions. Some attention is given to the dichotomy between electromagnetic and quantum theories with the illustration that one is used to describe the behavior of light and the other is used to describe the creation and detection of light—all within the same optical system.

The ideas mentioned above can be covered effectively in only one disciplined hour or so if they are presented as a series of rhetorical questions and concepts. For example, "What is light?" Concept 1: One view is that light is energy in the form of electromagnetic waves characterized by an electric vector and a magnetic vector. . . . Concept 2: An alternate view is that light is energy in the form of bundles, packets, or quanta that . . . . Concept 3: For many of the processes we are interested in, electromagnetic theory serves. In this approach, the interaction of light with materials can be described by a set of equations developed by many people over a long time, but which were augmented and made systematic by Maxwell. And so on.

### INTERFERENCE

Following presentation of the introductory material, the unifying concept of interference of waves is presented. This is the first cornerstone in optics. A simple demonstration of interference using a laser and Lloyd's mirror or Young's fringes, two optical flats to show Newton's rings, or a short photoelasticity demonstration is useful to set the stage and arouse curiosity. There are two parts to this section on interference. In the first, interference of collinear waves is discussed in detail using trigonometric notation. The important finding is that interference produces another wave of the same frequency but whose amplitude is dependent on the phase difference between the interfering waves. That the

phase difference can be determined to some degree by measurement of the irradiance of the resulting wave is emphasized as the most important fundamental idea in interference techniques. The second part is a phenomenological discussion of the oblique interference of two plane waves. Sufficient for the moment is the basic concept with emphasis on the fact that a grating-like structure is produced, and that this type of interference is fundamental in moire and holography.

### THE GENERIC INTERFEROMETER

The next step is the concept of the "generic interferometer." An illustration of such an imaginary device is shown in Figure 1. This model of measurement of path length difference by two-beam interference is very useful in that it establishes a universal paradigm for all interferometric measurement without reference to a particular technique. Emphasis is given the fundamental idea that detectors are insensitive to phase, so we convert phase difference to irradiance difference through the process of interference. This is also a good time to mention the main problem with interferometry, that absolute phase difference cannot be measured without additional information such as can be obtained by phase stepping, compensation, or the use of two wavelengths.

### DIFFRACTION

Although it is not actually needed at this point in the development, this is a good time to present the second cornerstone in optics, that being the concept of diffraction at an aperture and its implications for modifying optical information. Only the basic ideas are given at this stage, since the topic will be studied in detail when it is required for understanding of optical processing, moire, and holography. An introductory demonstration involves passing laser light through gratings and looking at the result on a screen. If available, a simple optical bench with a laser, a beam expander, two lenses, and a screen can be set up to show the diffraction patterns obtained when a plane wave falls on an aperture containing a transparency.

Emphasis is given the fact that when light passes through any aperture, whether or not there is a lens in place, the irradiance pattern downstream is proportional to the Fourier transform of the aperture. Analogies with audio signal processing are useful here, given that students know something

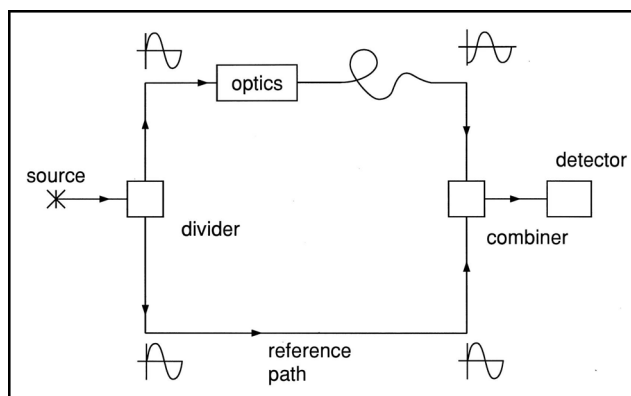

Fig. 1 Generic interferometer

## UNIFYING CONCEPTS IN OPTICAL METHODS

of that subject. In the optics form, spatial frequency in the input plane is converted to distance in the transform plane. That the frequency content of the information in the aperture can be modified in the transform plane and that a modified inverse transform can be created are discussed with some examples. For some reason, examples related to intelligence gathering seem quite effective. Bandwidth limit implications catch the imaginations of some, particularly photographers. "Do you really want to use the smallest possible aperture for landscape photography?"

### BASIC INTERFEROMETRIES

With the concepts mentioned above delivered, one can pass to some specific techniques that illustrate applications of the concepts, that are useful measuring methods, and that establish additional concepts. One approach is to use Newton's rings to develop the idea of interferometry based on amplitude division, and Young's fringes to illustrate wavefront division. Both of these interferometries are easily demonstrated in the classroom or laboratory, it being most effective to do the demonstration before any explanation is offered. Optical flats and a penlight serve to illustrate Newton's rings. A laser and a piece of aluminum foil with two small holes very close together will illustrate Young's fringes.

A useful goal can be accomplished by developing clearly for both these methods the relationships between interference fringe order, path length difference, and the parameter of interest, namely surface profile differences in the one case and pinhole separation in the other. These calculations are very simple in the context of these two interferometries, and the principles carry over to more complex methods. It is also worth mentioning that Young's fringes are used directly in the method of speckle photography to be studied later.

### PHOTOELASTICITY AS A PARADIGM

Whether or not Newton's and Young's interferometries are studied, it is appropriate but not necessary to study photoelasticity next. Photoelasticity serves as a useful instructional paradigm for two-beam common-path interferometry as well as being an important measurement tool. The important possibilities of photoelasticity for determining stress directions and magnitudes are shown using a couple of polarizers, a model, and an overhead projector. Also, the potential for obtaining accurate data in a quick and simple way near stress concentrations and singularities can be emphasized during this demonstration by using a model with some notches or section changes. Before getting into the subject as a measurement technique, some more unifying concepts are presented, including refraction, retardation, birefringence, and relative retardation. Once these ideas are understood, photoelasticity theory can be developed quickly, since all the required concepts have already been presented, and maximum attention can be given to the calculation of path difference as a function of principal refractive indices. That the birefringence in materials might be dependent on stress can be saved for later. The idea of photoelastic compensation can be presented as a precursor to what are now called phase stepping methods.

### HOLOGRAPHY AND HOLOGRAM INTERFEROMETRY

An important point is that with the concepts and tools in hand, instruction in any of the optical techniques can be pursued with little additional development. For example, suppose that photoelasticity is not of high priority, maybe because it is considered old-fashioned, but there is special interest in holographic methods. First, a white-light hologram and penlight can be passed around to arouse curiosity. One need only introduce complex notation and complex amplitude (actually, this is not necessary, it just makes the calculations easier) and a more complete discussion of oblique interference of two beams; then the development of holography theory can be finished in a half-hour or so, depending on the detail needed and the time available.

Here, the process of holography is presented as one involving interference to store the information and diffraction to retrieve it. All the rest is technical detail that can be discussed as time permits, and the students can begin lab experiments in holography right away. After presentation of the basic holographic process, hologram interferometry is considered as another application of the concept of two-beam interference. In its simplest form, this interferometry is only another visit with Newton's rings.

### SPECKLE PHOTOGRAPHY

The treatment of speckle methods is similar except that no additional concepts are necessary. A speckle pattern is first created in the classroom on a screen or the wall using a laser and simple beam expander. The students are asked to observe the changes in the speckle caused by: (a) slow small motions of the head; (b) changing the eye aperture by bringing the eyelids nearly closed. These demonstrate the relationships between speckle size and aperture, and that movement of either the observer or the specimen produce changes in the speckle pattern.

At this point, the concept of speckle photography can be developed and demonstrated in only a few minutes. The only important concepts are the formation of speckle, the fact that the speckle moves with the specimen, Young's fringes, and, in the case of whole-field processing, the modification of frequency content of a doubly-exposed speckle pattern by Fourier optical processing (diffraction). It is easy to demonstrate the use of Young's fringes to obtain surface displacements by passing around a double-exposure speckle photograph and a penlight. A basic speckle photography experiment is easy to set up, since it requires only an expanded laser beam, a specimen whose motion can be controlled, and a camera.<sup>2</sup>

This is also a good time to introduce the concept of white-light speckle photography, since no new ideas are required. Applications to geophysical problems seem to capture the imaginations of students.<sup>3</sup>

### SPECKLE INTERFEROMETRIES

The difference between speckle interferometries and speckle photography must be clearly established, both as to the fun-

## UNIFYING CONCEPTS IN OPTICAL METHODS

damental ideas and the applications, which augment one another.

In speckle interferometry, interference of multiple waves creates a certain irradiance within each subjective speckle, with this irradiance changing as movement of the specimen causes path length changes within each speckle. Diffraction concepts are important because the bandwidth of the lens affects speckle size.

The author finds that speckle interferometry is best explained by use of a thought experiment. Suppose a film is exposed to a speckle pattern from a cantilever beam so as to form a row of only 10 or so coarse speckles having random irradiances. The film is then developed, causing the dark speckles to form a hole in the emulsion (unexposed emulsion), the light speckles form opaque spots in the emulsion, and so on. The developed film is then placed exactly in its original location. It is easy to show that no light comes through the film, because the illuminated spots coincide with the opaque areas, and the holes in the emulsion have no light falling on them. But, what if the cantilever beam is deformed? The irradiances of the individual speckles change, so that now some illuminated speckles coincide with the holes in the emulsion. Imagine passing to a limit where there is a large number of small speckles. One can see that some sort of fringe pattern will form, but there will be many small gaps that reduce fringe visibility because of all those speckles that were originally light.

The reason for use of this thought experiment is that it emphasizes a unique aspect of speckle interferometry that is difficult to keep in mind, specifically that this interferometry uses only changes of irradiance in individual speckles. The fringe pattern formed is not, properly speaking, an interference fringe pattern at all. Experience suggests that referring to speckle correlation phase maps as "fringes" impedes full understanding of these methods. A corollary is that the speckle size is not fundamentally important as long as the two patterns are registered so as to facilitate direct subtraction of one irradiance from the other.

Once the fundamental concept is understood, one observes that, since speckle size need not be small, electronic/digital imaging devices can be used to record the irradiances in in-

dividual speckles for each state of the specimen, and the subtraction of irradiances can be performed in a computer. So, here we have an interferometry method that is compatible with electronic imaging and data processing. Experiments to demonstrate simple subtraction electronic speckle interferometry are simple and inexpensive to set up and run.<sup>4</sup>

As these ideas are developed, the limitation of interferometries in determining absolute path length changes will be obvious. Phase stepping can be introduced as a method to obtain absolute path length changes; it can be introduced as an extension of the compensation techniques studied with photoelasticity.

### CONCLUDING REMARKS

The purpose of this paper is to outline a workable flexible approach to the teaching of optical methods of experimental mechanics. Specific techniques were chosen for illustration. There is no intent to slight or diminish other important methods such as geometric moire, moire interferometry, shearography, laser doppler, caustics, and so on.

The examples cited above establish a paradigm for teaching at different levels and under serious time constraints. Maximum use is made of unifying concepts and sequential organization of the material to exploit transfer of learning.

The approaches were developed by trial and error over many years. They will certainly evolve further with time and practice. A long-term goal is to teach the physics and the techniques with maximum efficiency so that they need not be dropped from crowded engineering curricula.

### References

1. Cloud, G.L., *Optical Methods of Engineering Analysis*, London, Cambridge University Press, (1995, 1998).
2. Cloud, G.L., Practical Speckle Interferometry for Measuring In-Plane Deformations, *Applied Optics* **14**, 4, 878-84 (1975).
3. Conley E. and Cloud, G., Whole-field Measurement of Ice Displacement and Strain Rates, *Journal of Offshore Mechanics and Arctic Engineering*, **110**, 169-171, (1988).
4. Cloud, G.L., Speckle Interferometries Made Simple and Cheap, *Proc. 2000 International Congress on Experimental, Theoretical and Experimental Mechanics*, Society for Experimental Mechanics, Bethel, Connecticut, June 2000. ■