

Effects of Aliasing and Preventing it in Test Instrumentation

Chris Gibson

VTI Instruments

- Introduction
- Definitions
 - ADC Basics
 - Nyquist Theorem
 - Aliasing
- Concerns – Why is this important to me?
- Analog Anti-Alias Filters
- Digital Decimation/Anti-Alias Filters

ADC Basics- SAR ADC

- SAR (Successive Approximation Converter)
 - Medium to high speed >10Mhz
 - Medium to high resolution (12 to 16 bit)

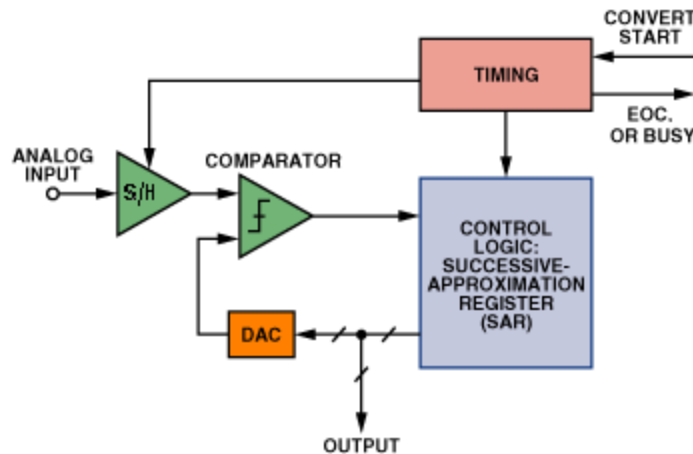

ADC Basics- Sigma/Delta ADC

- Sigma Delta ADC
 - Very high resolution (16 to 24 bit)
 - Highly oversampled, but lower sample rate

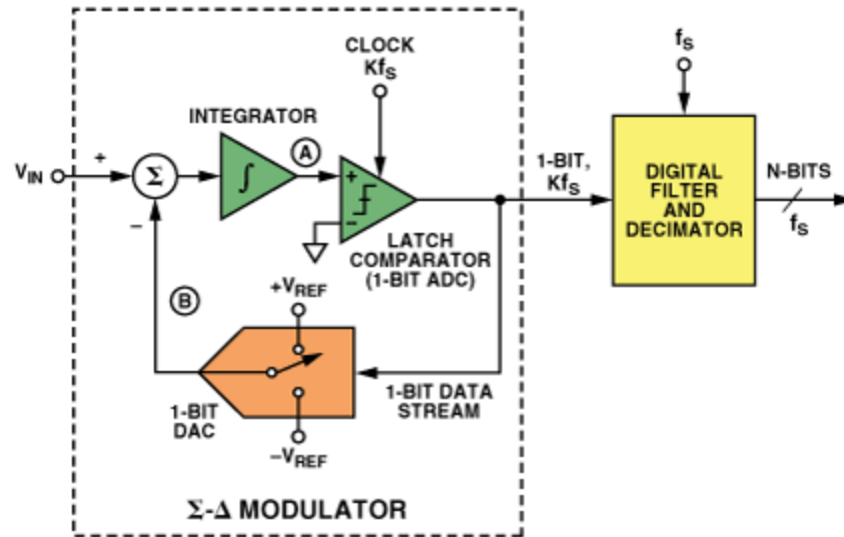

Typically 64 or 128 x oversampled

Nyquist Theorem

- **Nyquist theorem**: states that a signal must be sampled at a rate greater than twice the highest frequency component of interest in the signal to capture the highest frequency component of interest; otherwise, the high-frequency content will alias at a frequency inside the spectrum of interest (pass-band).
- $f_s > 2 * \text{highest frequency component of interest}$



Aliasing

- Aliasing due to unwanted, spurious out-of-band signals is a problem in many applications that use A/D converters. These signals, if not filtered properly, can seriously impact the performance of a data-conversion system.
- If a signal is sampled at a sampling rate smaller than twice the Nyquist frequency, false lower frequency component(s) appears in the sampled data. This phenomenon is called Aliasing. Hence if the signal is not sampled often enough, information is irretrievably lost.
- If a signal is sampled once per period, a DC signal, with arbitrary amplitude, is generated.

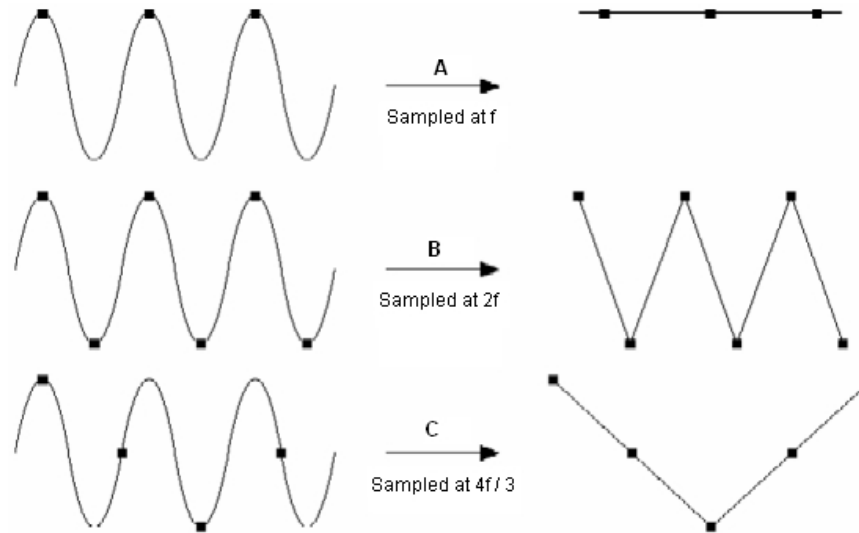

Aliasing Example

- If a 5 MHz sine wave digitized by a 6 MS/s ADC, the dotted line indicates the aliased signal recorded by the ADC. The 5 MHz frequency aliases back in the pass-band, falsely appearing as a 1 MHz sine wave.

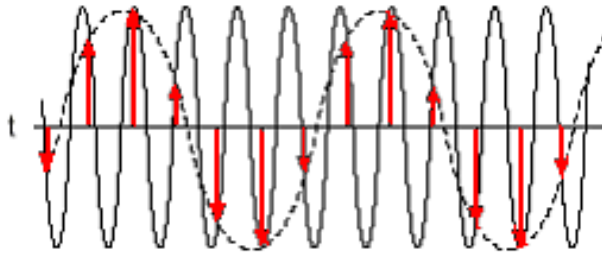

The solid line represents the actual input signal and the dotted line represents the reconstructed signal from the samples. The red arrows indicate the instance of samples.

Alias frequency is the absolute value of the difference between the frequency of the input signal and the closest integer multiple of the sampling rate.

Alias Freq. = ABS Closest Integer Multiple of Sampling Freq. – Input Freq

(where ABS = absolute value)

Aliasing Example

Example: Assume f_s , the sampling frequency, is 100 Hz and that the input signal contains the following frequencies: 25 Hz, 70 Hz, 160 Hz, and 510 Hz. These frequencies are shown in the following figure.

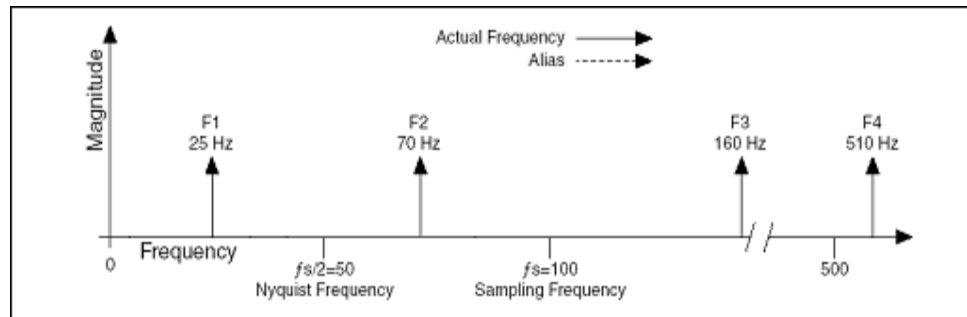

As shown in the following figure, frequencies below the Nyquist frequency ($f_s/2 = 50$ Hz) are sampled correctly. Frequencies above the Nyquist frequency appear as aliases. For example, F1 (25 Hz) appears at the correct frequency, but F2 (70 Hz), F3 (160 Hz), and F4 (510 Hz) have aliases at 30 Hz, 40 Hz, and 10 Hz, respectively

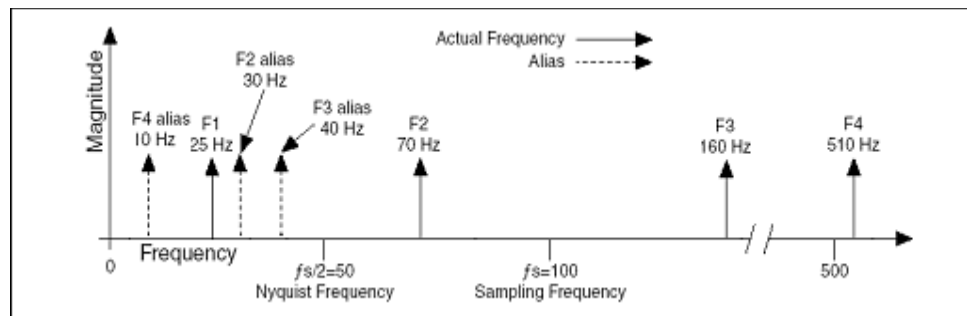

$$\begin{aligned} \text{Alias } F2 &= |100 - 70| = 30 \text{ Hz} \\ \text{Alias } F3 &= |(2)100 - 160| = 40 \text{ Hz} \\ \text{Alias } F4 &= |(5)100 - 510| = 10 \text{ Hz} \end{aligned}$$

Analog Anti-Alias Filter

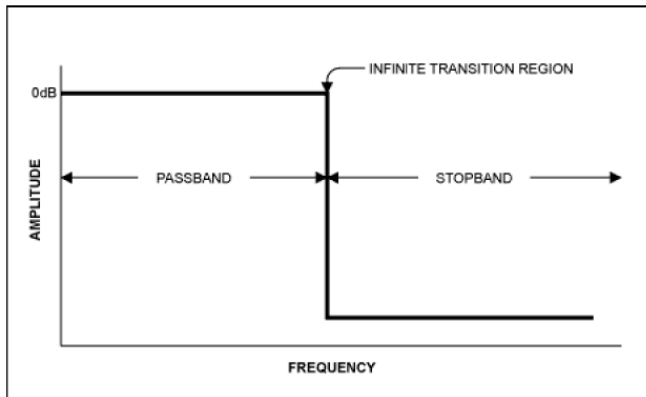
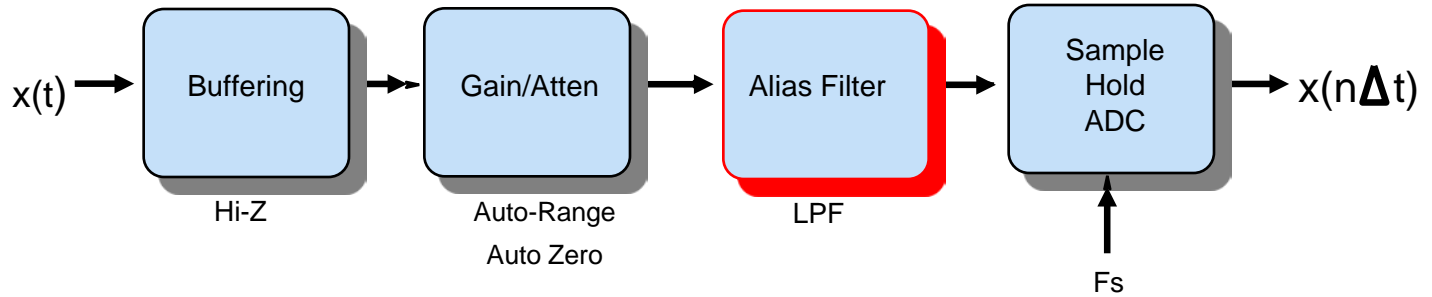

Ideal filter (perfect cutoff)

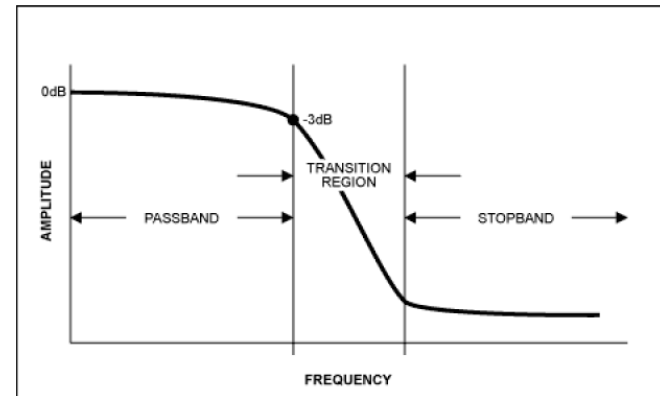

Real filter (some roll-off)

Most common filter types

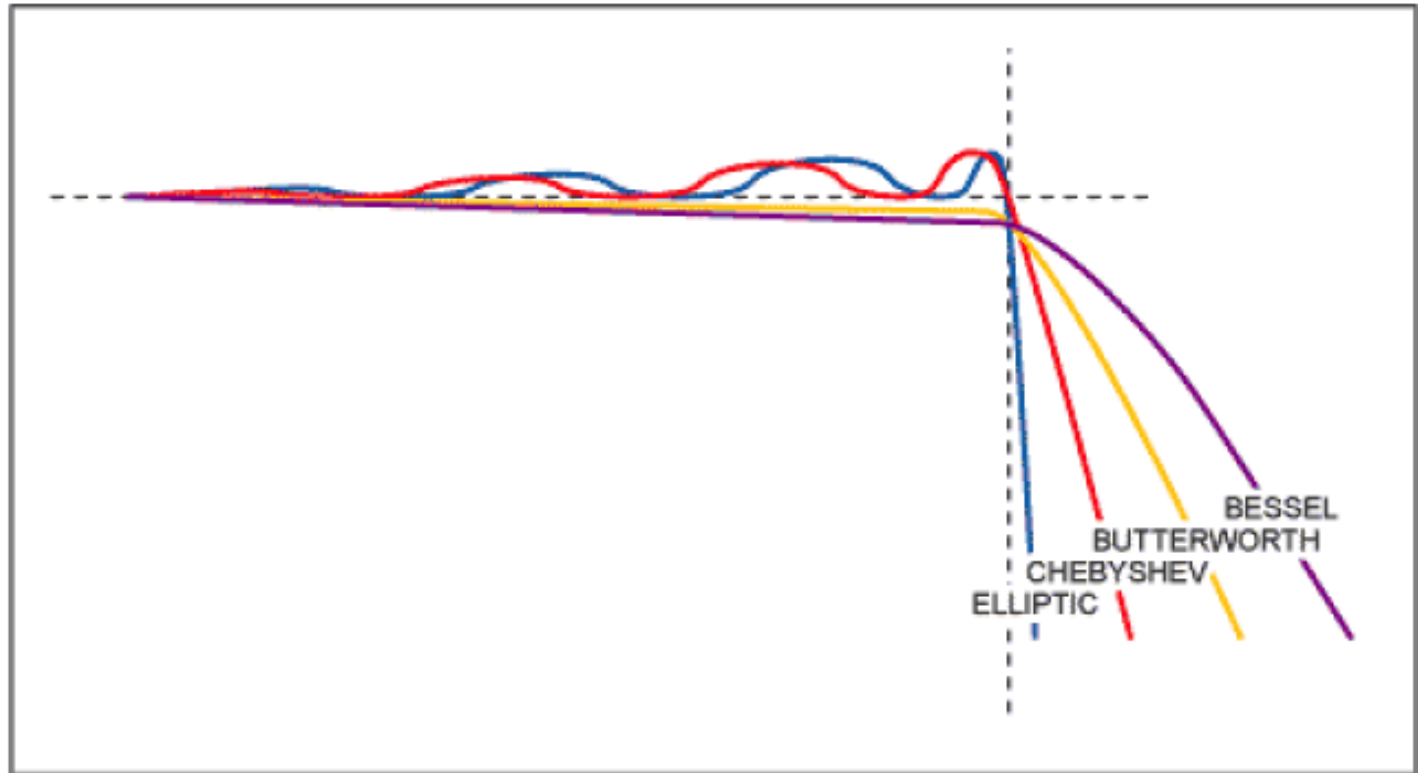

Analog Anti-Alias Filter design Criteria

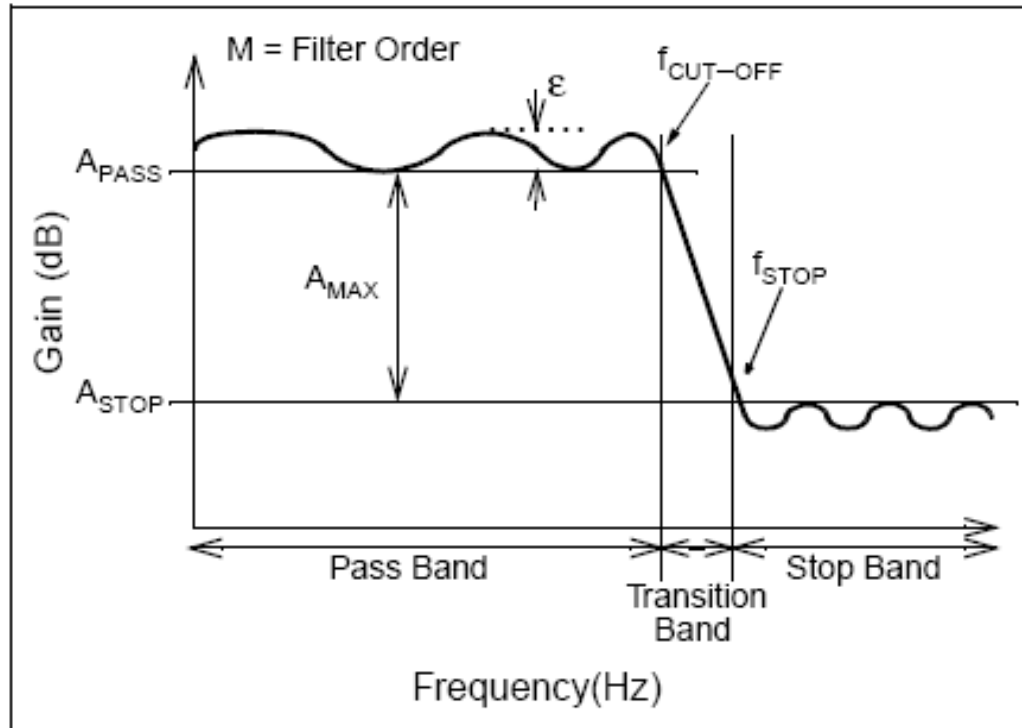

Filter Design Criteria

- Flatness in the passband
- Roll-off (# of filter poles)
- Phase response

Frequency Domain Response of Common AA Filters

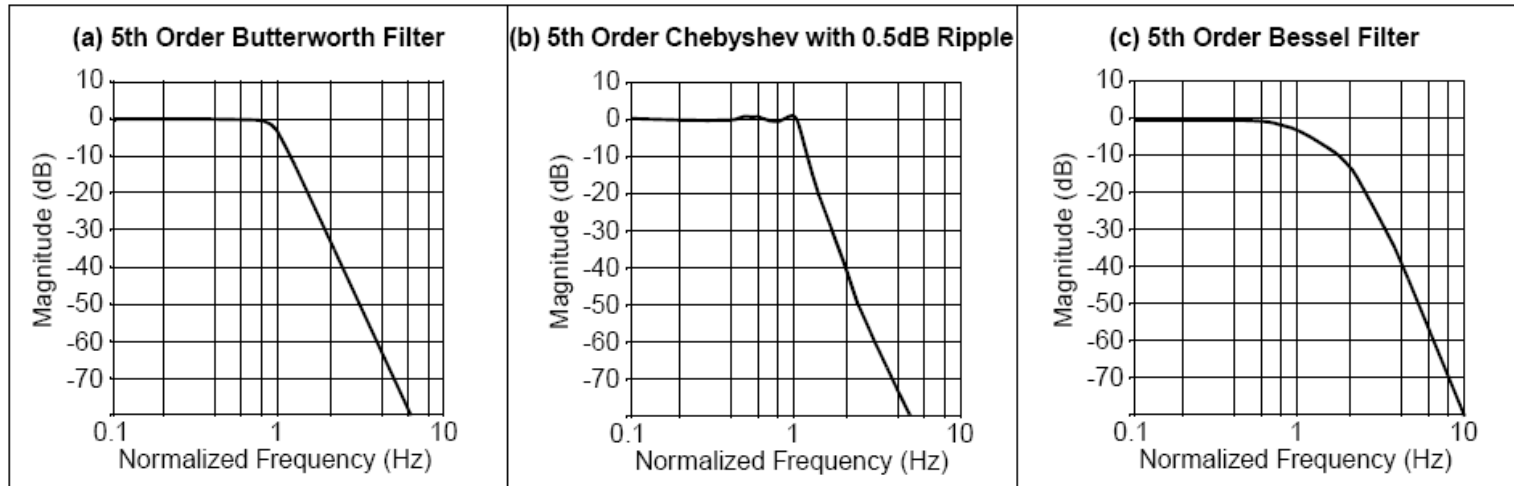

Typical Filter Characteristics

- Butterworth: Flat in the pass band
- Chebyshev: Good response all the way to the cut off frequency
- Bessel: Linear phase response

Step response of Common AA Filters

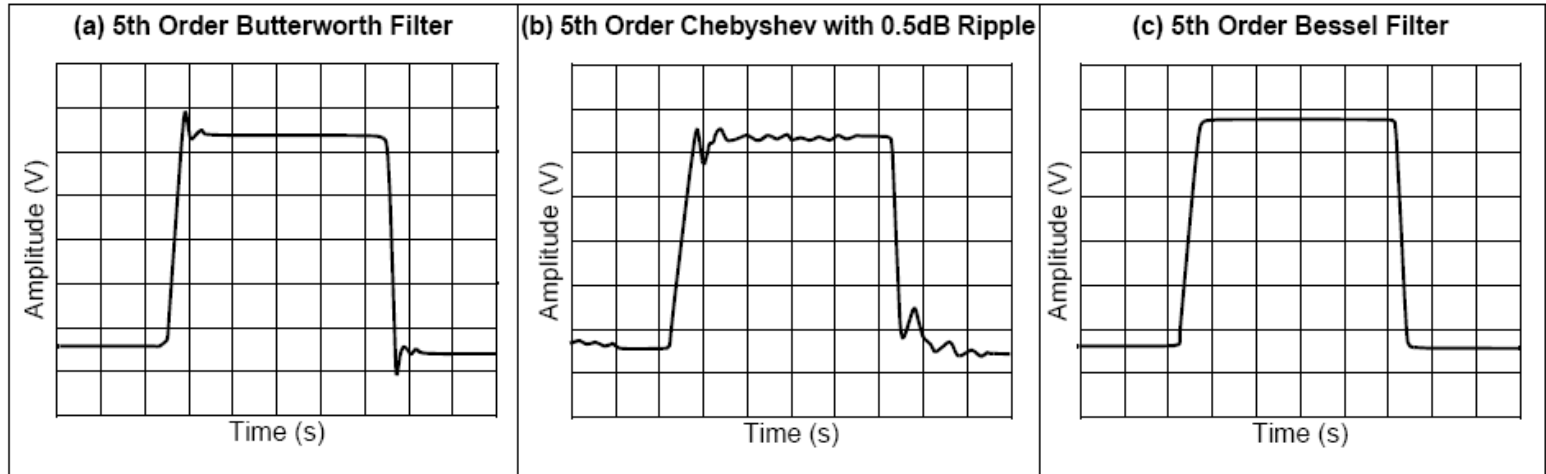

Sources of “out of band energy”

- Accelerometer self resonance
- Typical AC Power Noise (60hz, 120hz, 180hz, etc)
- Out of band energy or electrical noise

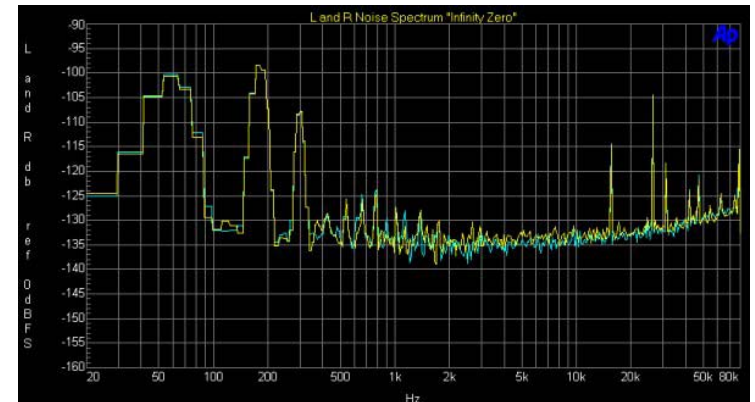
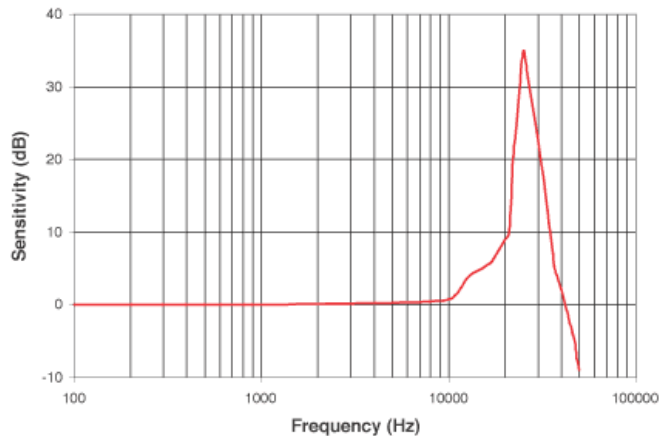

Advantages of oversampled ADC's

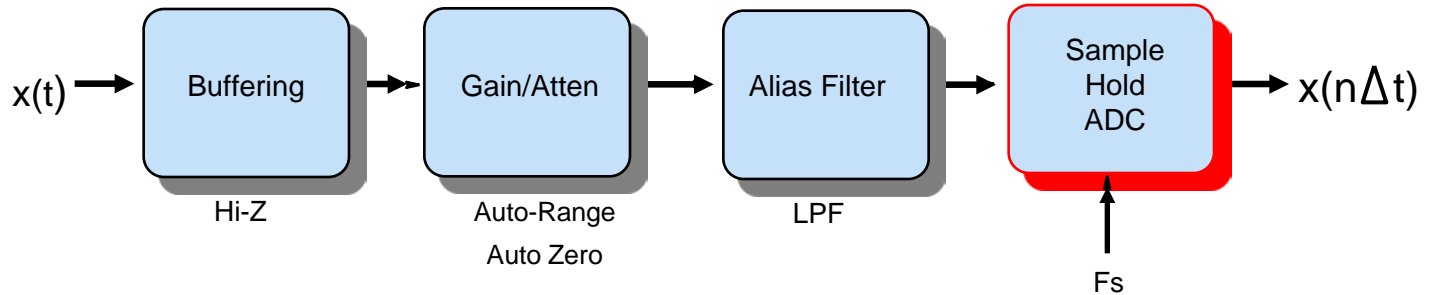

Example

102Ksa/sec

SAR/Flash type ADC

fs=

Sample Rate

fs/2(Nyquist)

102K

102Ksa/sec

51Khz

Sigma Delta ADC

fs=

Sample Rate

fs/2

102K

102K * 128 = 13.05 Msa/sec

6.5 Mhz

Digital Filtering (Decimation)

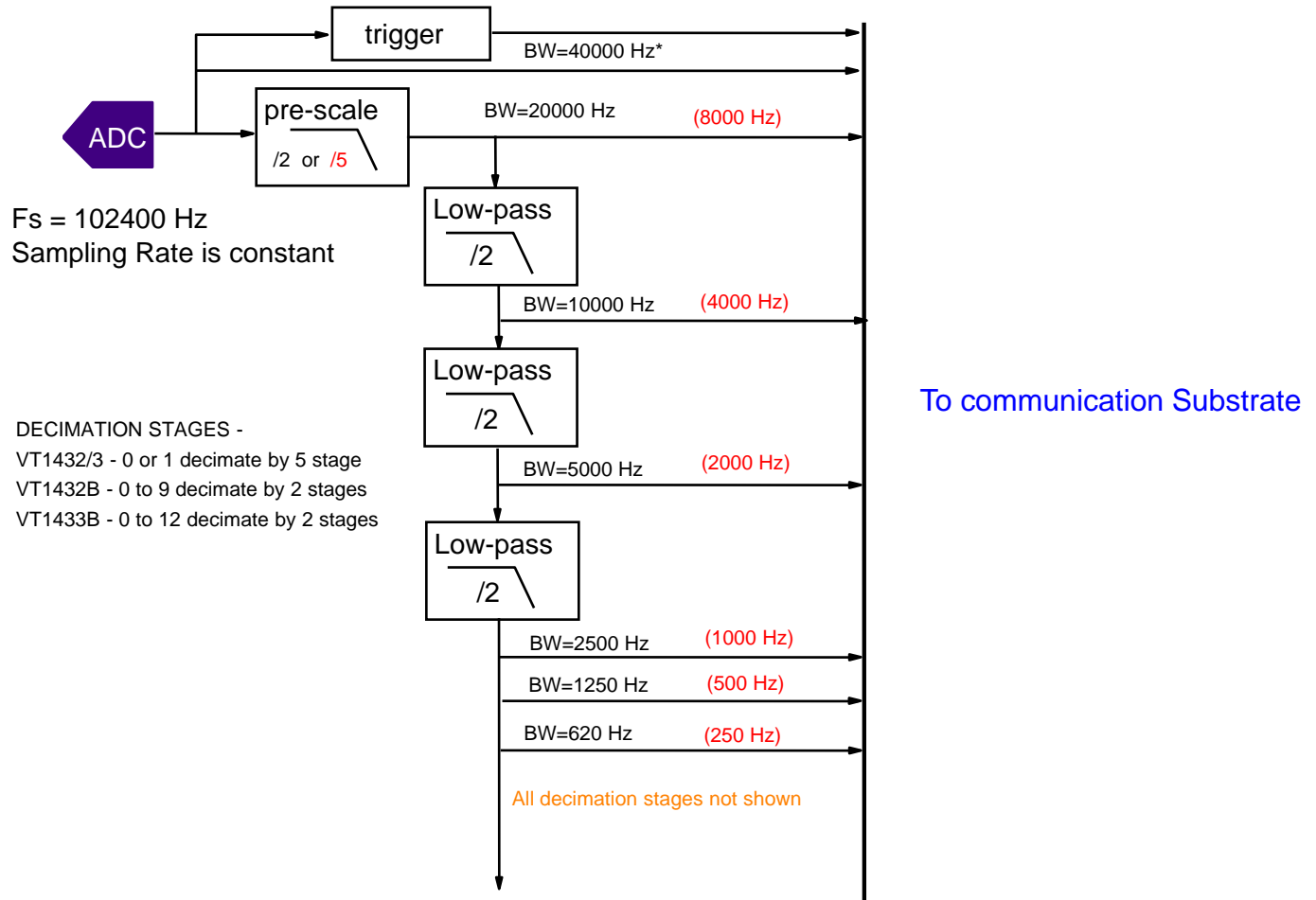

Dynamic range and bits

$$\text{dB} = 20 \log 2^N \text{ (number of ADC bits)}$$

12 bits	72 dB
14 bits	84 dB
16 bits	96 dB
24 bits	144 dB

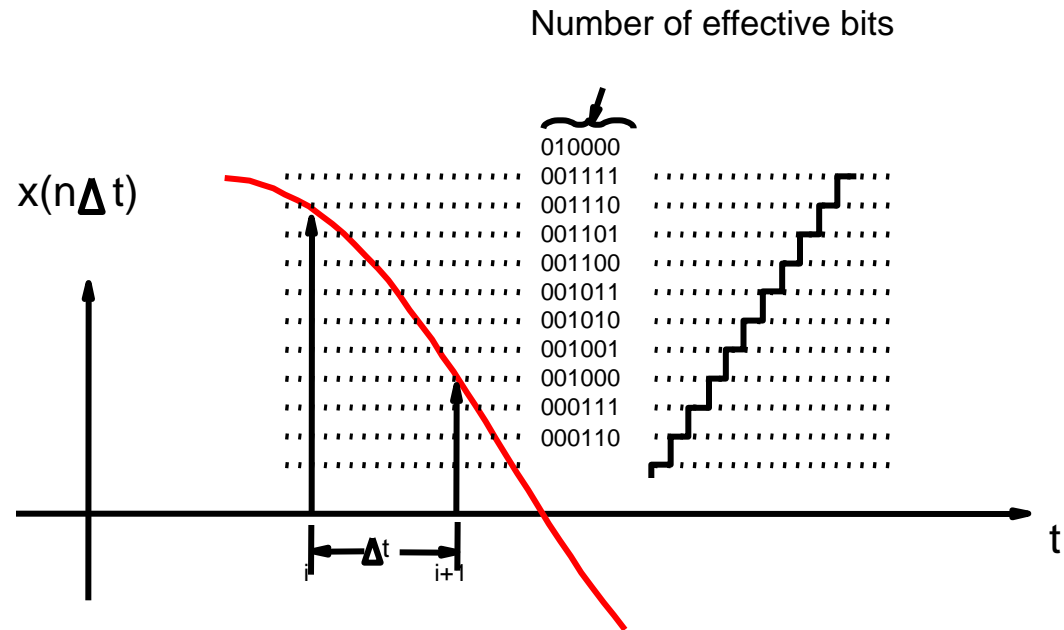

Protected bandwidth vs Nyquist

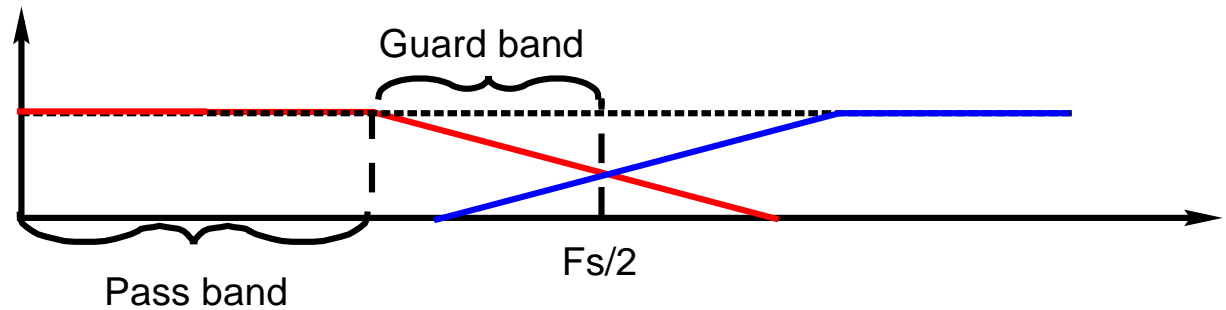

Block size	64	128	256	512	1024	2048	4096	8192
FFT lines	32	64	128	256	512	1024	2048	4096
Final lines	25	50	100	200	400	800	1600	3200

Effects of Digital Anti-Alias filters

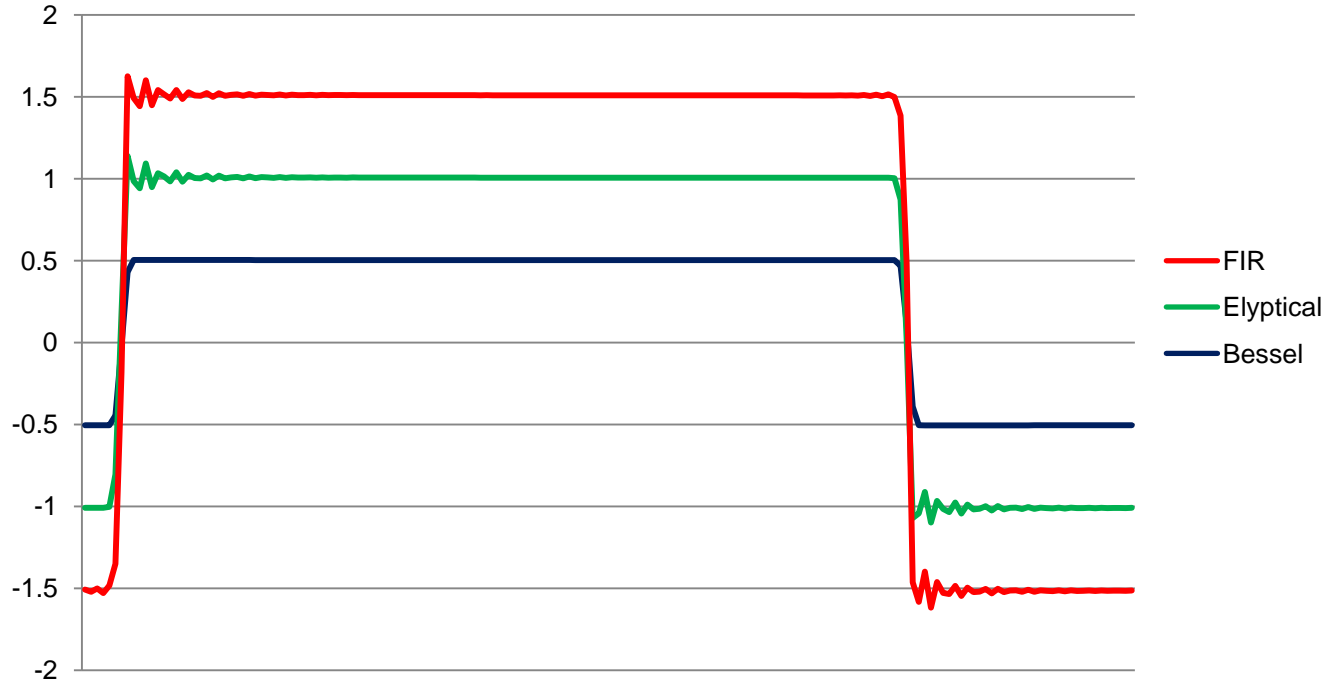

In this example, a 500hz Square wave was input to a DSA system that is capable of selecting 3 different Digital Anti-Alias filter shapes (FIR, Elliptical, and Bessel). Data was sampled at 25Ksa/sec. Data is offset to show filter ringing

Summary

- Care should be taken to make sure that no aliased data is acquired. Once digitized, there is no going back
- Users should understand the characteristics of the system used for data acquisition purposes
 - This includes the type of ADC used
 - Analog Anti Alias filters used
 - Digital Decimation or Anti Alias filters used
- Use the right tools for the type of testing
 - A system optimized for frequency domain testing might not provide optimum results for transient testing or impulse testing

References

- Microchip AN699: Anti-Aliasing, Analog filters for Data Acquisition Systems
- Maxim Application Note 298; Filter Basics, Anti Aliasing